

1497-5

04/19

# Montageanleitung

(bitte zusammen mit Kaufbeleg aufbewahren)

# Assembly instructions

(please retain and file together with the purchase receipt)

# Notice de montage

(à conserver et à accrocher impérativement avec le justificatif d'achat)

# Montagehandleiding

(samen met de aankoopfactuur in ieder geval bewaren)

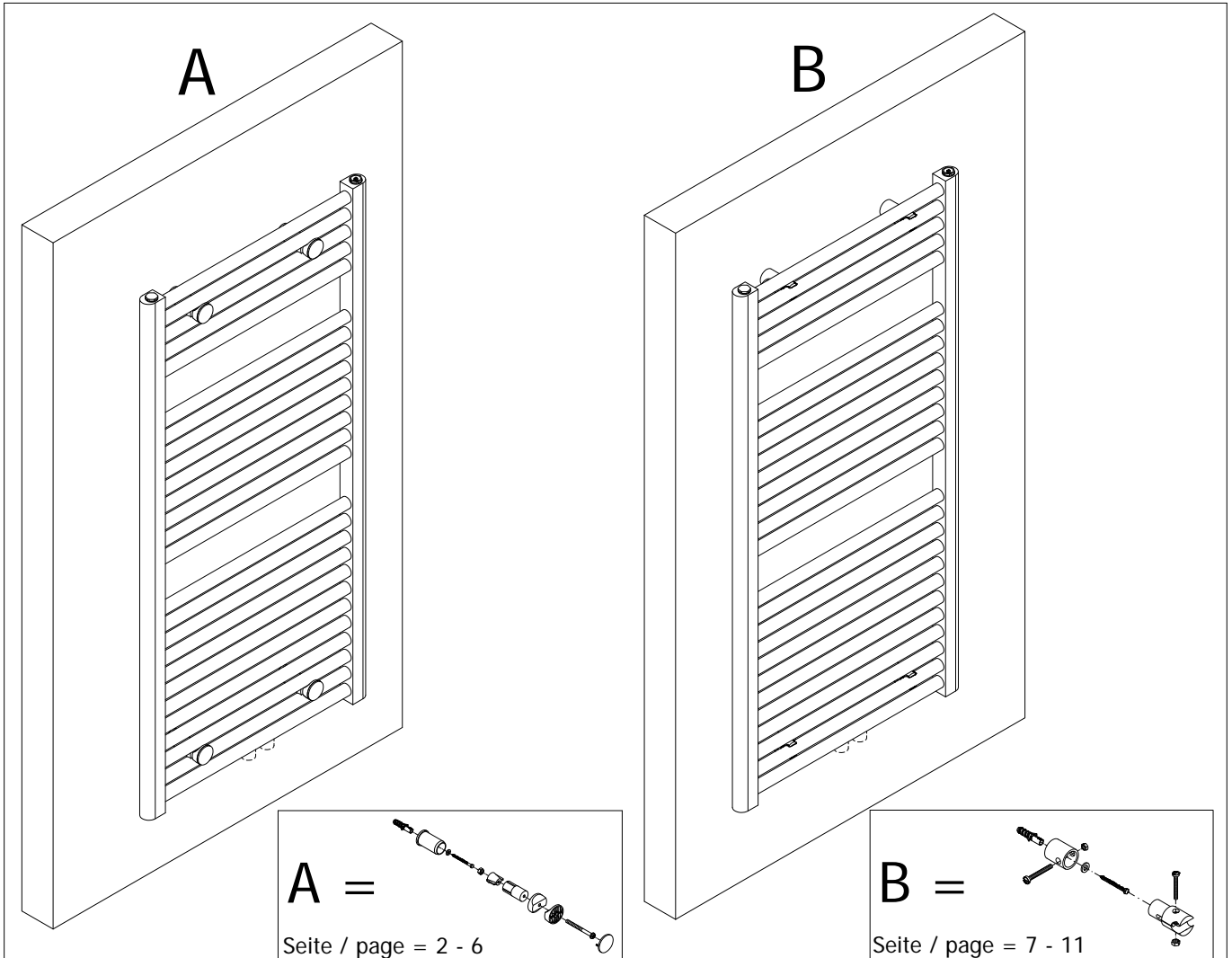







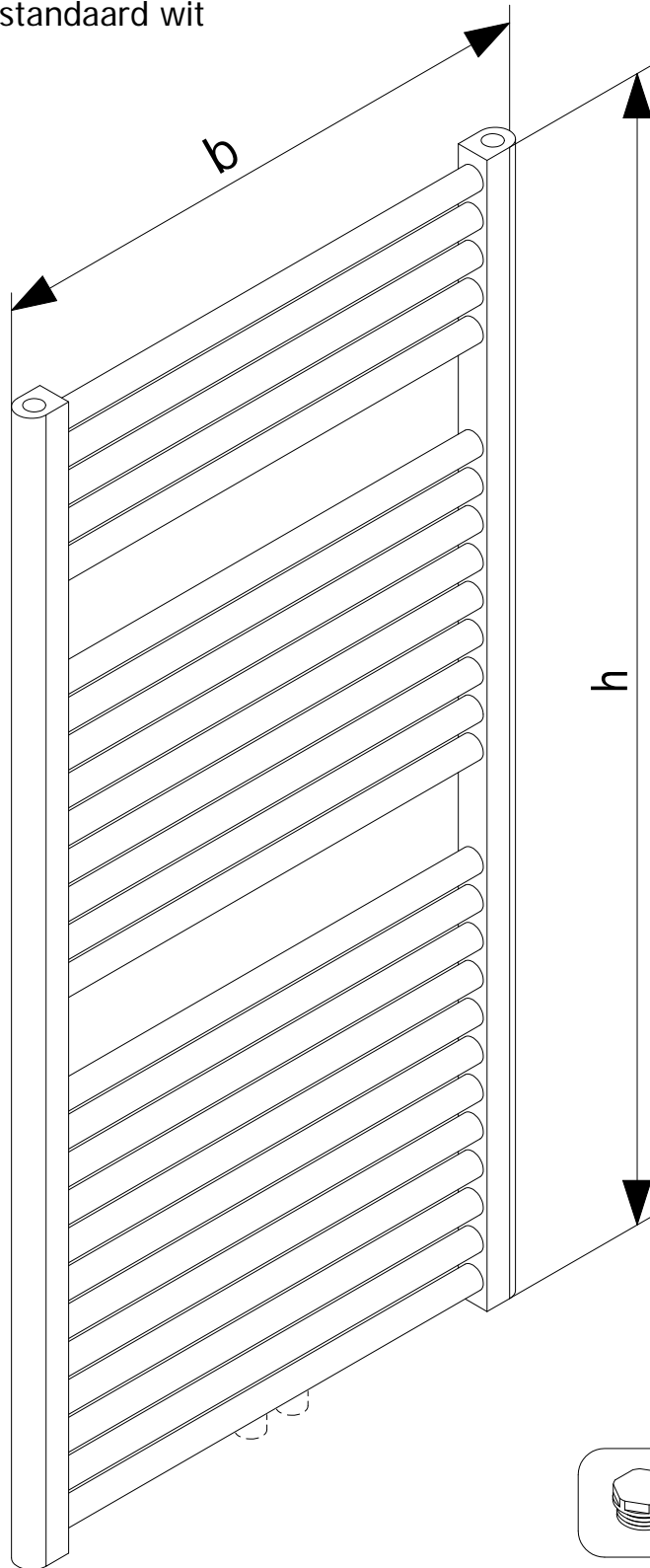



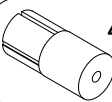

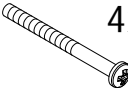
<b>CE</b>	<b>CE</b>	<b>CE</b>	<b>CE</b>
1015	1015	1015	1015
13 LINE	13 LINE	13 LINE	13 LINE
<p>EN 442-1 in der gültigen Fassung EN/HSK-Nr.02/2019-01 Gebrauch nur in Heizungsanlagen in Gebäuden</p> <p><b>Feuerbeständigkeit:</b> A1 <b>Freisetzung gefährlicher Stoffe:</b> keine <b>Druckdichtigkeit:</b> keine Undichtigkeit bei 1,3 x MB <b>Druckfestigkeit:</b> - kein Riss bei 1,69 x MB - Maximaler Betriebsdruck (MB) 10 bar</p> <p><b>Oberflächentemperatur:</b> bis 95°C; <b>Nennwärmeleistung:</b> 543 - 1411 W</p> <p><b>Beständigkeit:</b> <b>Korrosionsbeständigkeit:</b> keine Korrosion nach 100 h Feuchtigkeit <b>Beständigkeit gegen kleinere Stoßbeschädigungen:</b> Klasse 0</p>	<p>EN 442-1 valid version EN/HSK-Nr.02/2019-01 Heating systems in buildings</p> <p><b>Reaction to fire:</b> A1 <b>Release of dangerous substance:</b> none <b>Pressure tightness:</b> no leakage at 1,3 x MOP <b>Resistance to pressure:</b> - no breakage at 1,69 x MOP - Maximum operating pressure (MOP) 10 bar</p> <p><b>Surface temperature:</b> Maximum 95°C; <b>Rated thermal output:</b> 543 - 1411 W</p> <p><b>Durability as:</b> <b>Resistance against corrosion:</b> no corrosion after 100 h humidity <b>Resistance against minor impact:</b> Class 0</p>	<p>EN 442-1 version valable EN/HSK-Nr.02/2019-01 Pour installation dans les systèmes de chauffage</p> <p><b>Résistance au feu:</b> A1 <b>Rejet de substances dangereuses :</b> aucun <b>Étanchéité à la pression:</b> pas de fuite à 1,3 x PMA <b>Résistance à la pression:</b> - Pas de fissure à 1,69 x PMA - Pression de service Maxi. Autorisée (PMA) : 10 bars</p> <p><b>Température de surface:</b> jusqu'à +95°C <b>Puissance thermique nominale :</b> 543 - 1411 W</p> <p><b>Résistance:</b> <b>Résistance à la corrosion :</b> aucune apparition de corrosion après 100 h de test en milieu humide <b>Résistance aux légers impacts :</b> Degré 0</p>	<p>EN 442-1 in de geldige versie EN/HSK-Nr.02/2019-01 Gebruik alleen in verwarmingsinstallaties in gebouwen</p> <p><b>Vuurresistentie:</b> A1 <b>Vrijkomen gevaarlijke stoffen:</b> geen <b>Drukresistentie:</b> geen lekkage bij 1,3 x MB <b>Drukvastheid:</b> - scheurt niet bij 1,69 x MB - Maximale bedrijfsdruk (MB) 10 bar</p> <p><b>Oppervlakte temperatuur:</b> tot 95°C <b>Nominale warmteafgifte:</b> 543 - 1411 W</p> <p><b>Resistentie:</b> <b>Corrosie resistentie:</b> geen corrosie na 100u vochtigheid <b>Resistentie tegen kleinere stootbeschadigingen:</b> Klasse 0</p>

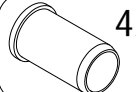
- Ⓓ Produktübersicht Standardfarbe weiß
- ⒼⒷ product overview standard color white
- Ⓕ Aperçu produit couleur standard blanc
- Ⓐ productoverzicht standaard wit

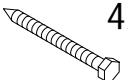
**A**



-  4x
-  4x
-  4x
-  4x
-  4x
-  4x
-  4x
-  4x
-  4x
-  4x
-  1x
-  1x oder or ou of
-  3x\*

Benötigtes Werkzeug / Tool needed / outillage nécessaire / Benodigd gereedschap

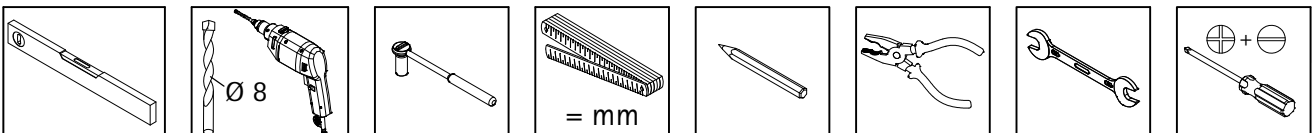

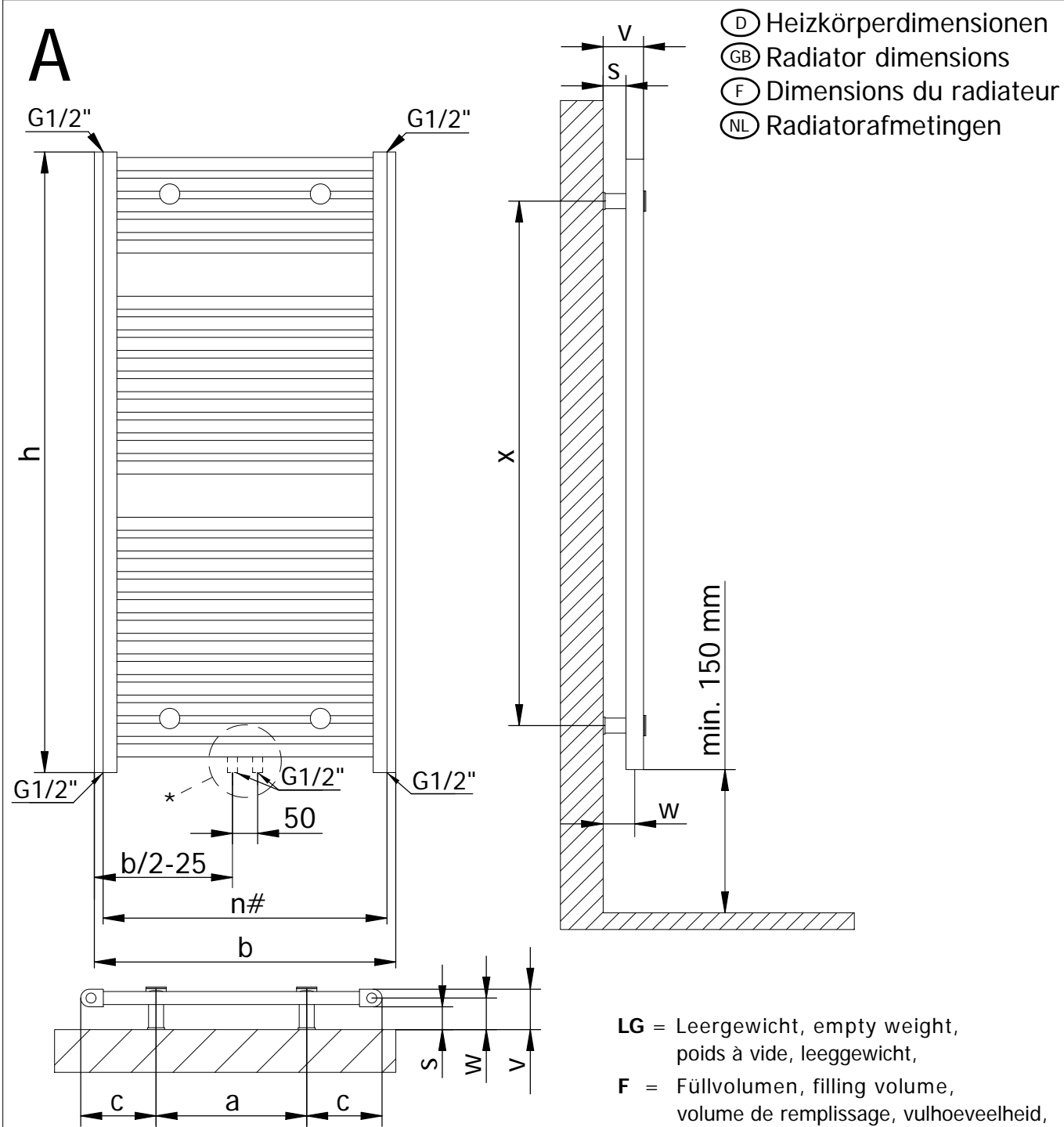

\* - Nur bei Heizkörpern mit Mittelanschluss.  
 \* - only radiators with center connection.  
 \* - Uniquement pour les radiateurs à raccord central.  
 \* - alleen bij radiatoren met middenaansluiting.

# - ist bedeutungslos bei Heizkörpern mit Mittelanschluss.  
 # - irrelevant in case of radiator with centre connector.  
 # - Sans importance pour les radiateurs à raccord central.  
 # - is onbelangrijk bij radiatoren met middenaansluiting.

h	b	n#	a	c	x	w	s	v	LG (kg)	F (L)	Watt
1215	400	360	250	75	1040	73-83	56-66	91-101	10,0	6,3	543
1775	400	360	250	75	1600	73-83	56-66	91-101	14,6	9,2	766
775	500	460	300	100	600	73-83	56-66	91-101	7,8	4,8	443
1215	500	460	300	100	1040	73-83	56-66	91-101	12,0	7,4	667
1775	500	460	300	100	1600	73-83	56-66	91-101	17,4	10,8	941
775	600	560	300	150	600	73-83	56-66	91-101	9,1	5,5	532
1215	600	560	300	150	1040	73-83	56-66	91-101	13,9	8,6	800
1575	600	560	300	150	1400	73-83	56-66	91-101	17,7	11,0	985
1775	600	560	300	150	1600	73-83	56-66	91-101	20,2	12,5	1.129
1215	750	710	400	175	1040	73-83	56-66	91-101	16,8	10,3	1.000
1775	750	710	400	175	1600	73-83	56-66	91-101	24,5	15,0	1.411

1 A

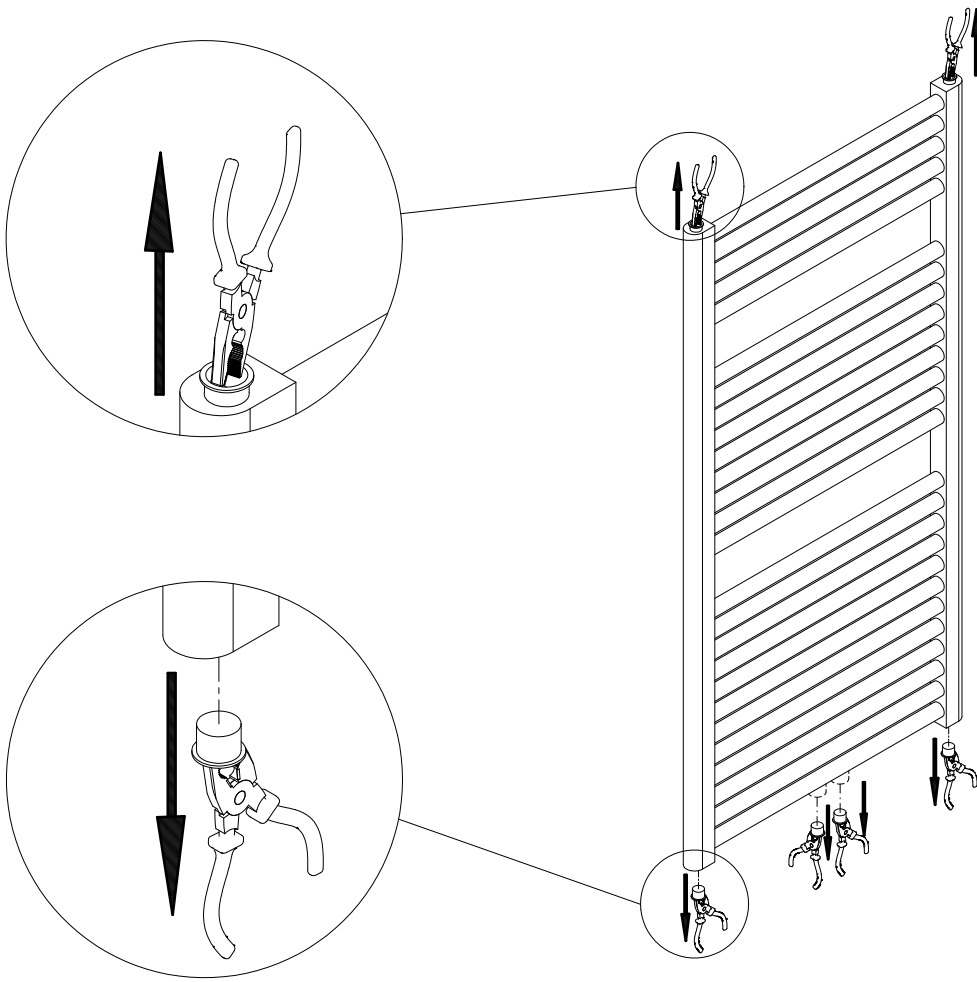

2 A

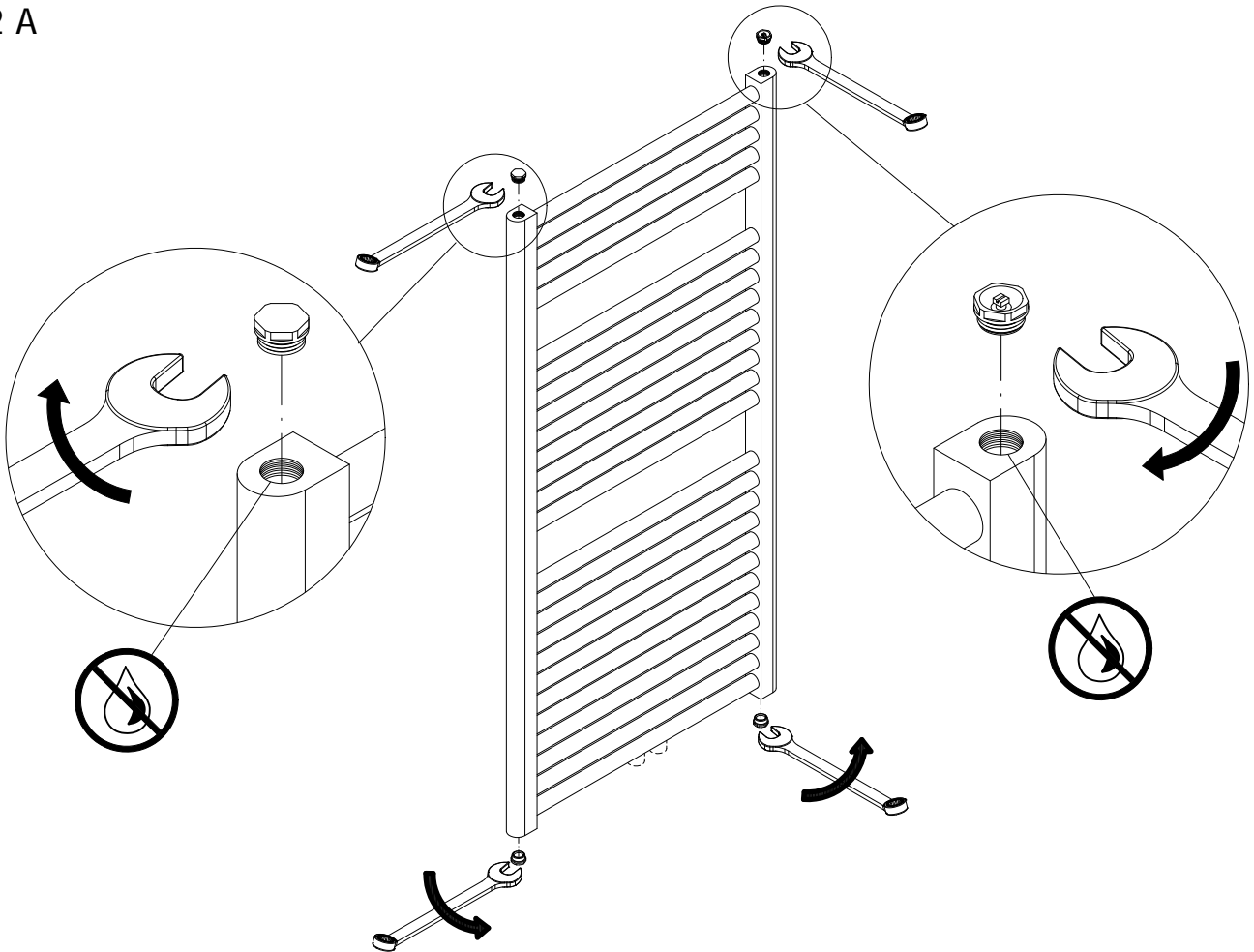

3 A

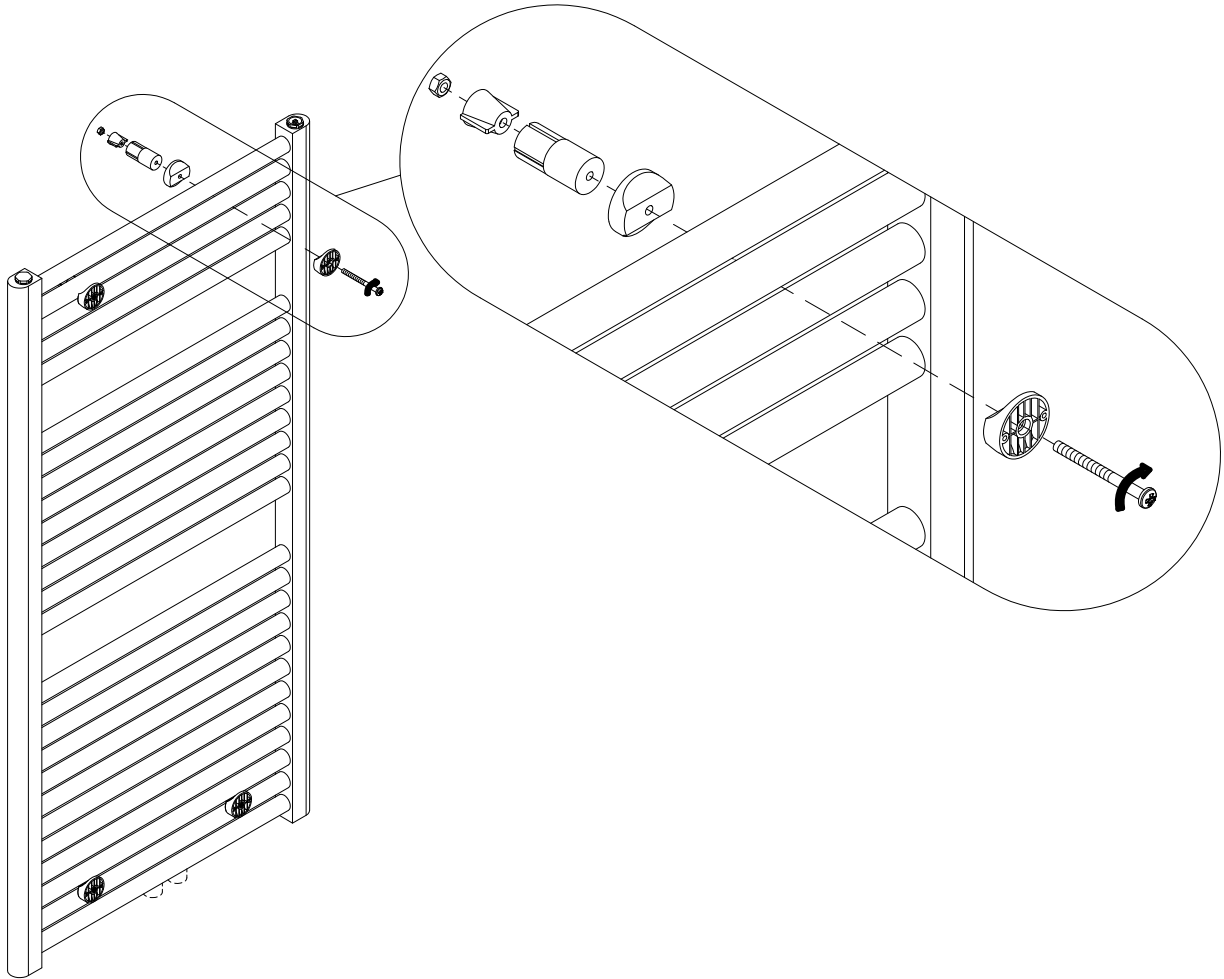

4 A

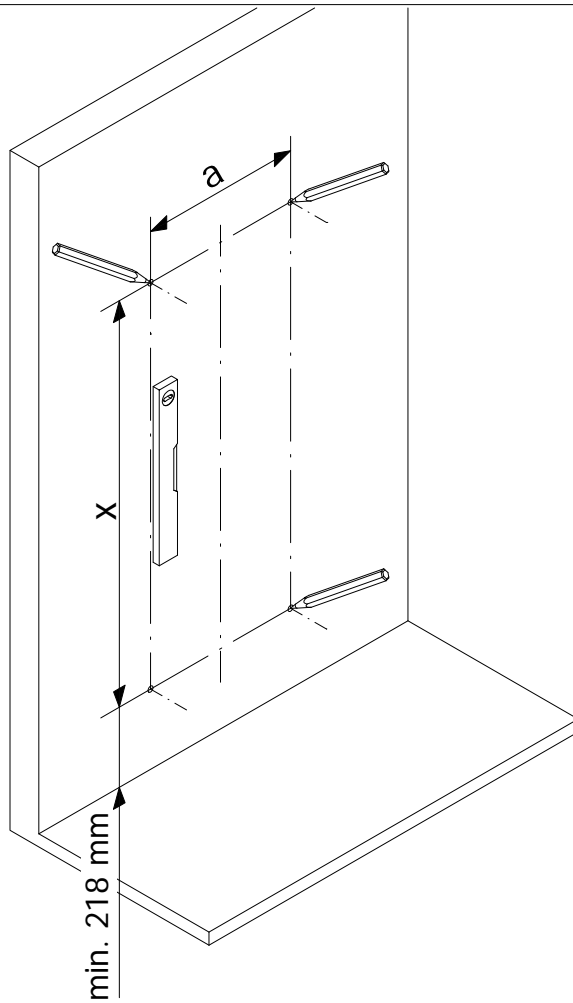

5 A

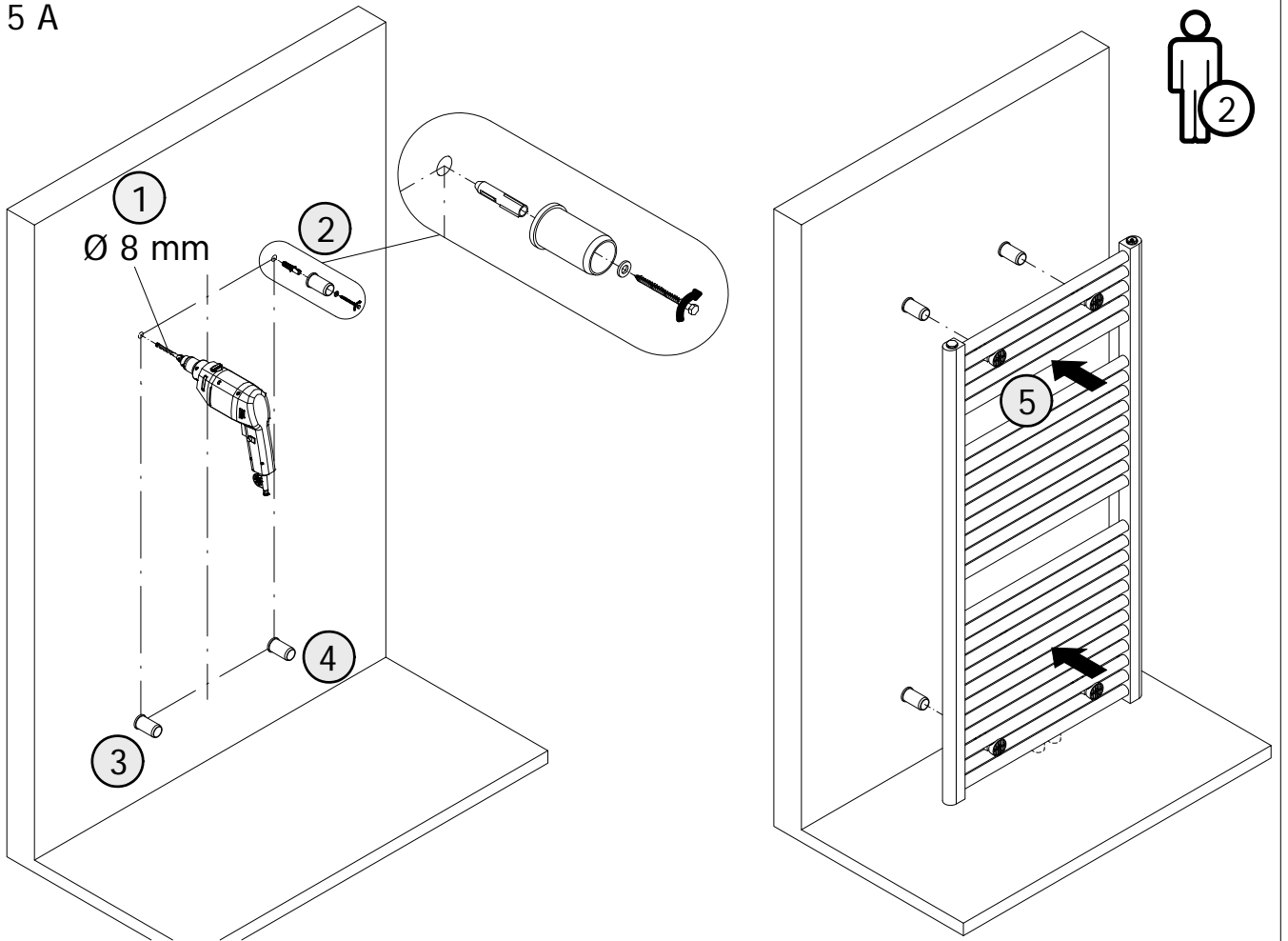

6 A

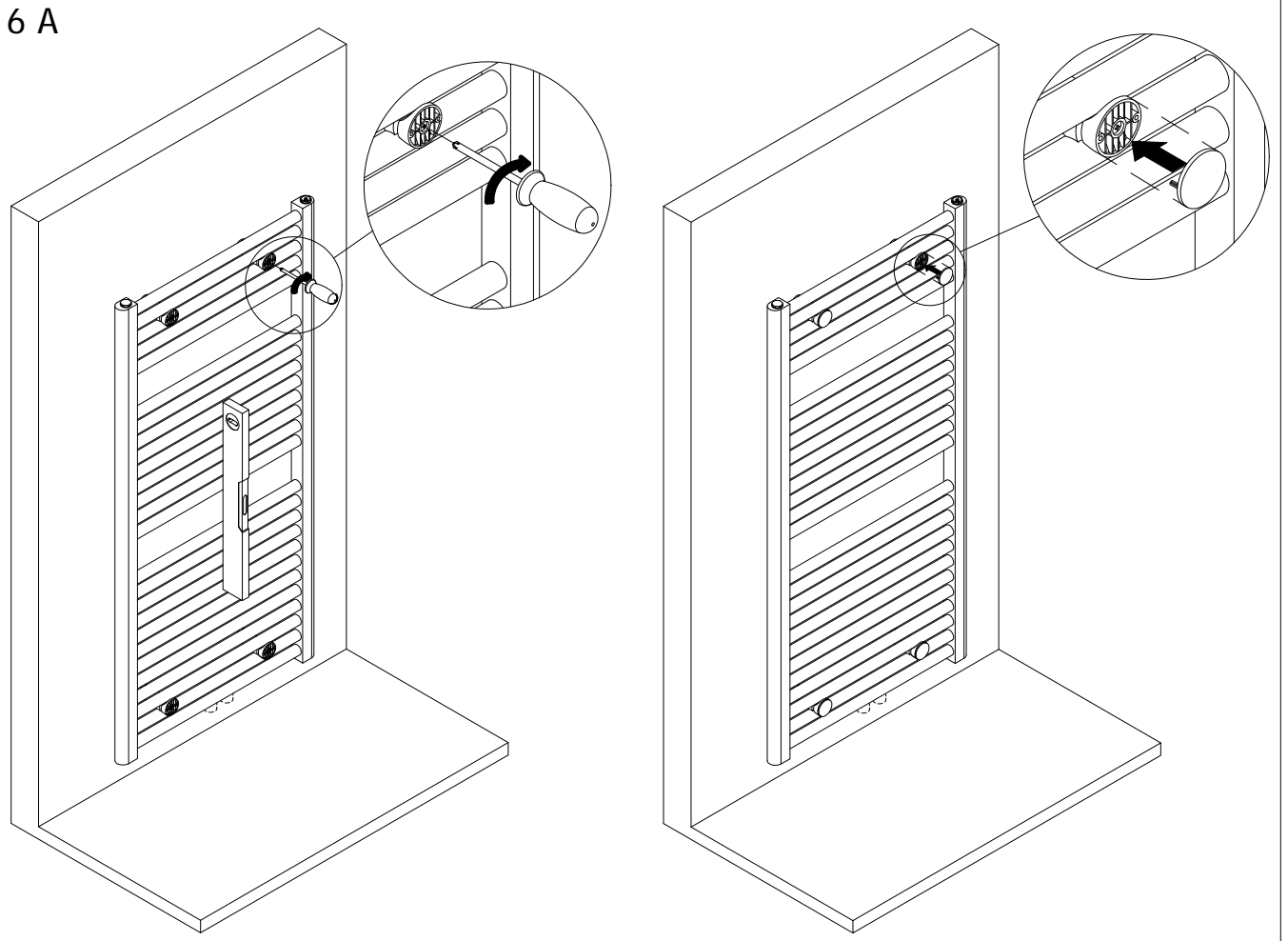

- Ⓓ Produktübersicht Sonderfarben
- ⒼⒷ product overview special colors
- Ⓕ Aperçu produit couleurs spéciales
- ⒸⓁ productoverzicht speciale kleuren

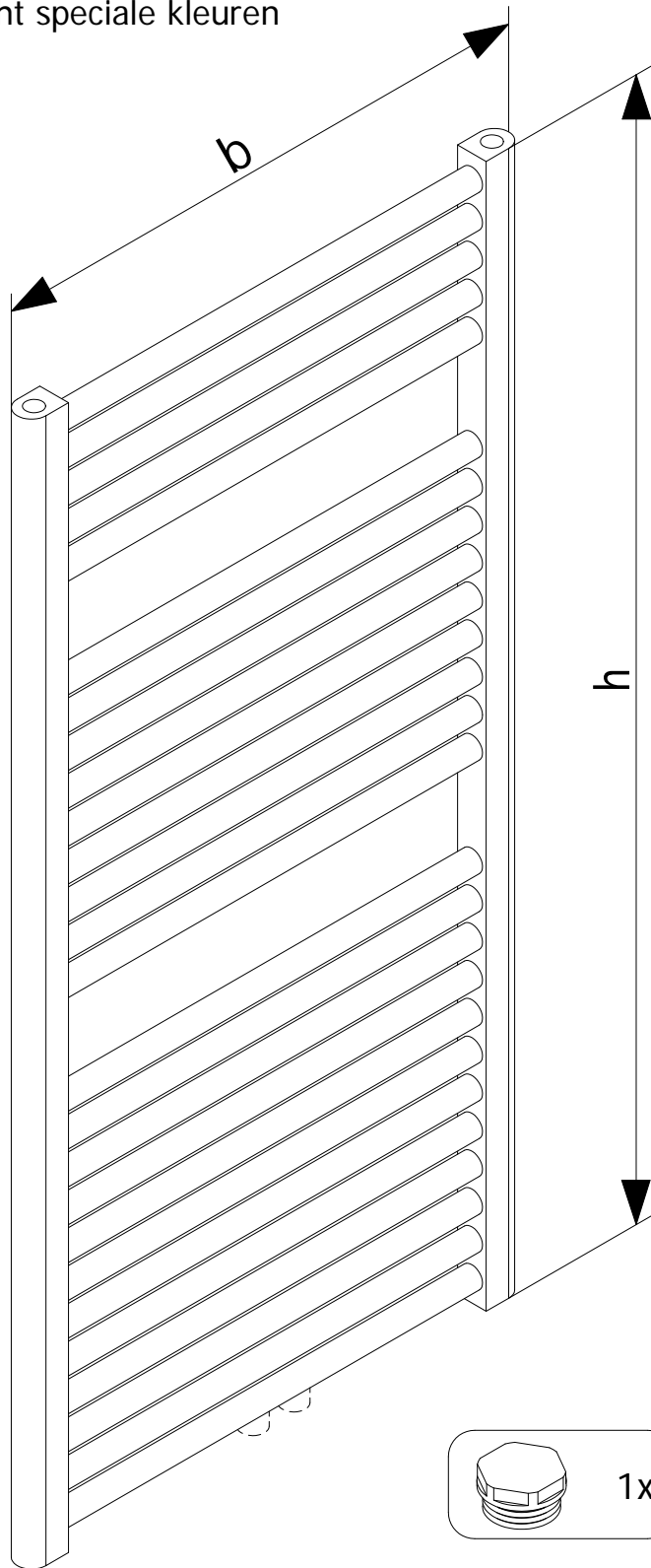

**B**

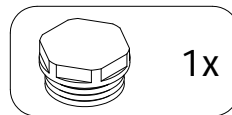
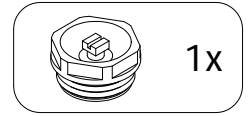
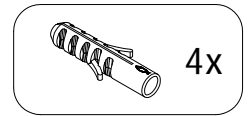
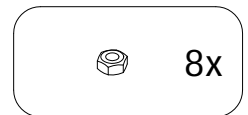
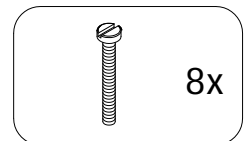
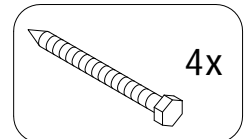
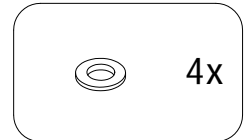
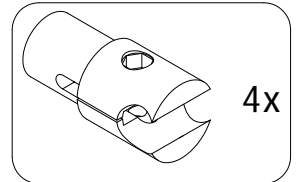
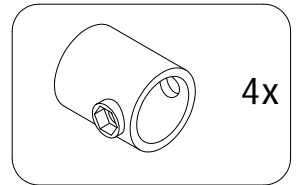

oder  
or  
ou  
of

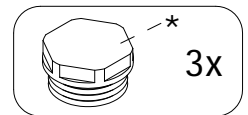

Benötigtes Werkzeug / Tool needed / outillage nécessaire / Benodigd gereedschap

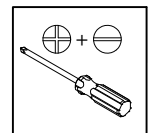
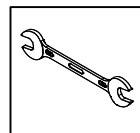
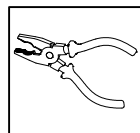
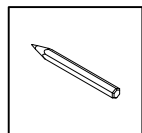
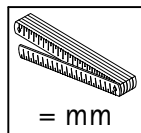
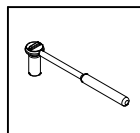
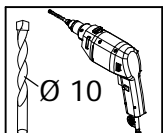
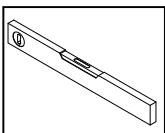

# B

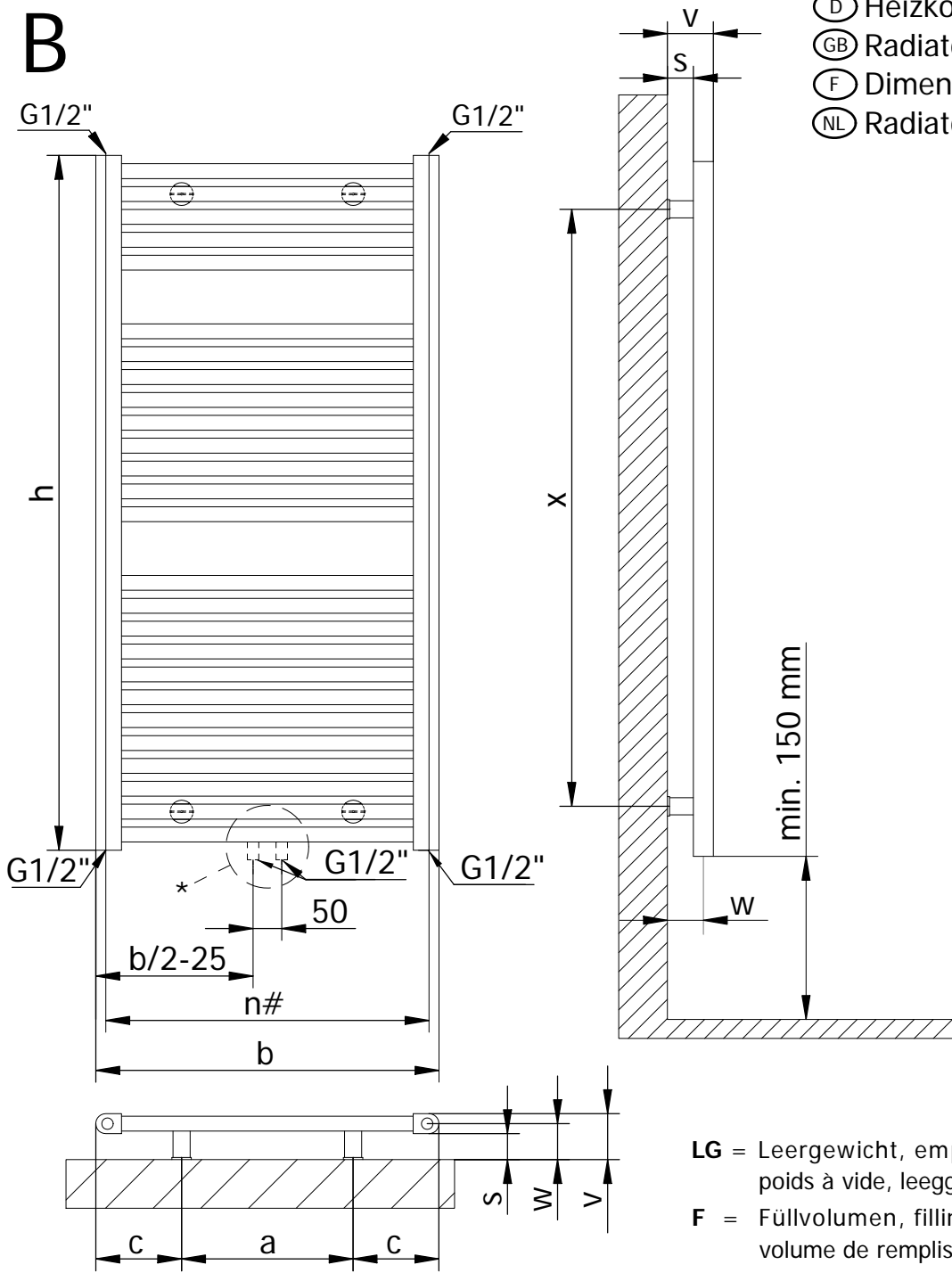

- Ⓓ Heizkörperdimensionen
- ⒼⒷ Radiator dimensions
- Ⓕ Dimensions du radiateur
- ⒼⓃ Radiatorafmetingen

**LG** = Leergewicht, empty weight, poids à vide, leeggewicht,  
**F** = Füllvolumen, filling volume, volume de remplissage, vulhoeveelheid,

- \* - Nur bei Heizkörpern mit Mittelanschluss. # - ist bedeutungslos bei Heizkörpern mit Mittelanschluss.
- \* - only radiators with center connection. # - irrelevant in case of radiator with centre connector.
- \* - Uniquement pour les radiateurs à raccord central. # - Sans importance pour les radiateurs à raccord central.
- \* - alleen bij radiatoren met middenaansluiting. # - is onbelangrijk bij radiatoren met middenaansluiting.

h	b	n#	a	c	x	w	s	v	LG (kg)	F (L)	Watt
1215	400	360	250	75	1080	69-79	51-61	86-96	10,0	6,3	543
1775	400	360	250	75	1640	69-79	51-61	86-96	14,6	9,2	766
775	500	460	300	100	640	69-79	51-61	86-96	7,8	4,8	443
1215	500	460	300	100	1080	69-79	51-61	86-96	12,0	7,4	667
1775	500	460	300	100	1640	69-79	51-61	86-96	17,4	10,8	941
775	600	560	300	150	640	69-79	51-61	86-96	9,1	5,5	532
1215	600	560	300	150	1080	69-79	51-61	86-96	13,9	8,6	800
1575	600	560	300	150	1440	69-79	51-61	86-96	17,7	11,0	985
1775	600	560	300	150	1640	69-79	51-61	86-96	20,2	12,5	1.129
1215	750	710	400	175	1040	69-79	51-61	86-96	16,8	10,3	1.000
1775	750	710	400	175	1640	69-79	51-61	86-96	24,5	15,0	1.411



1 B

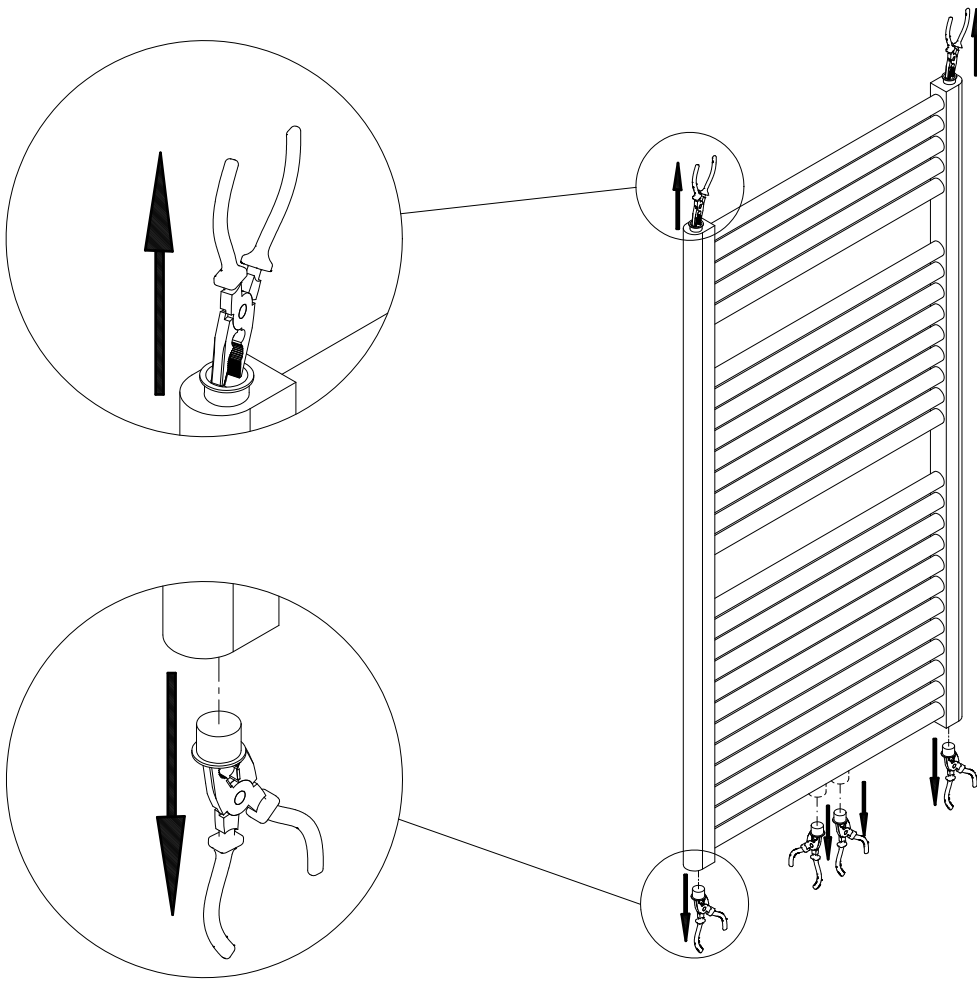

2 B

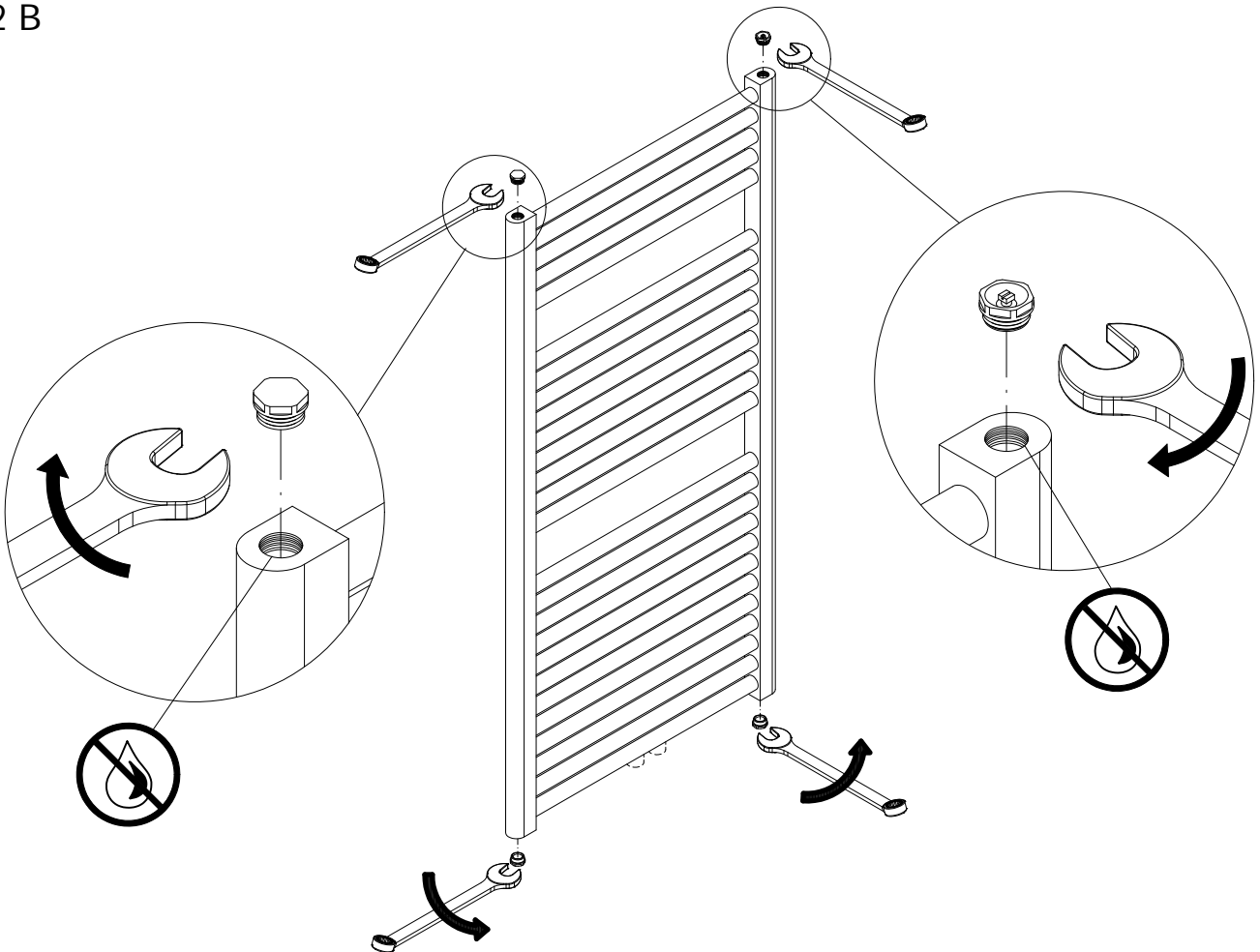

3 B

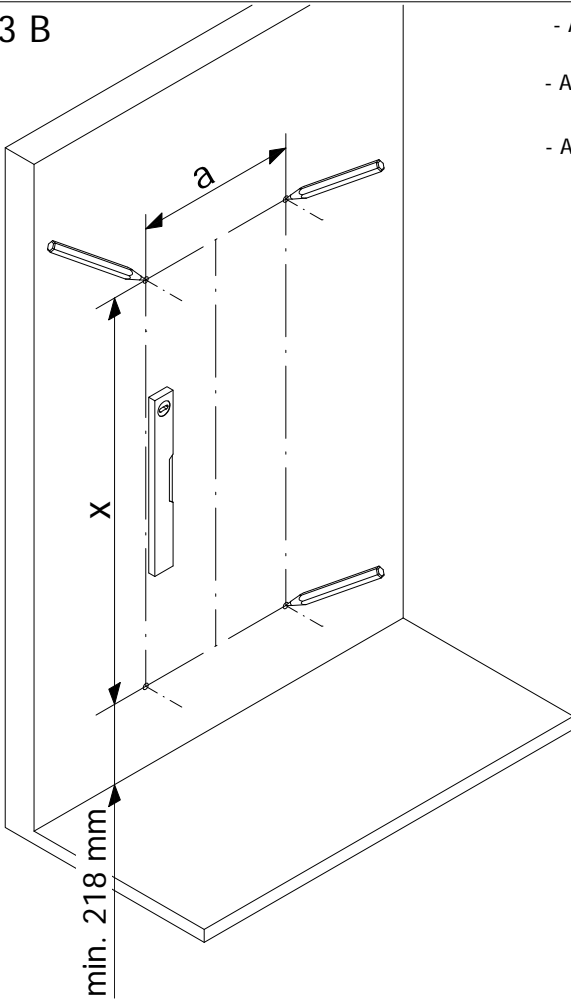

- Achtung: Bei farbigen Heizkörpern werden je nach Bauhöhe 3 bzw. 4 Metallbefestigungen geliefert.
- Attention: in case of coloured radiators there are depending on the installation height either 3 or 4 metallic fixations included within delivery.
- Attention: En fonction de leur taille, les radiateurs de couleur sont livrés avec 3 ou 4 fixations métalliques.
- Let op: Bij gekleurde radiatoren worden afhankelijk van de bouwhoogte 3 resp. 4 metaalbevestigingen geleverd.

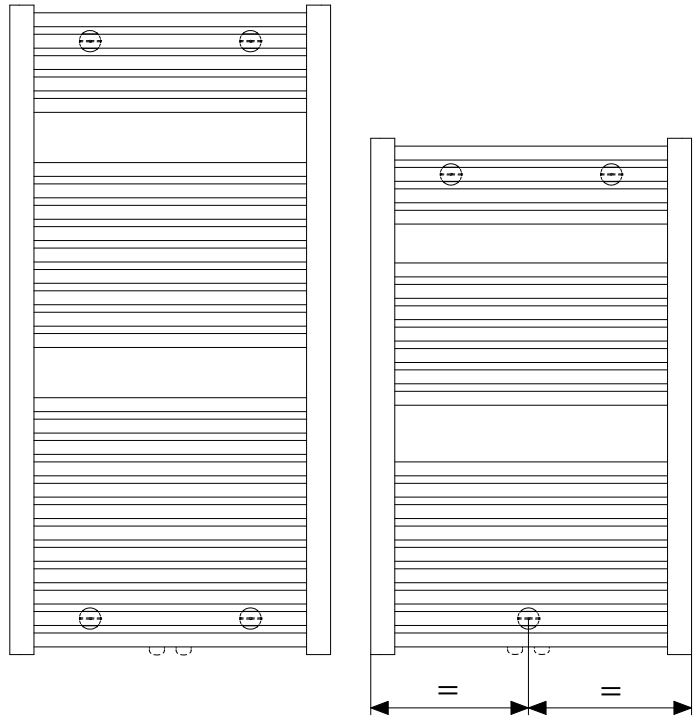

4 B

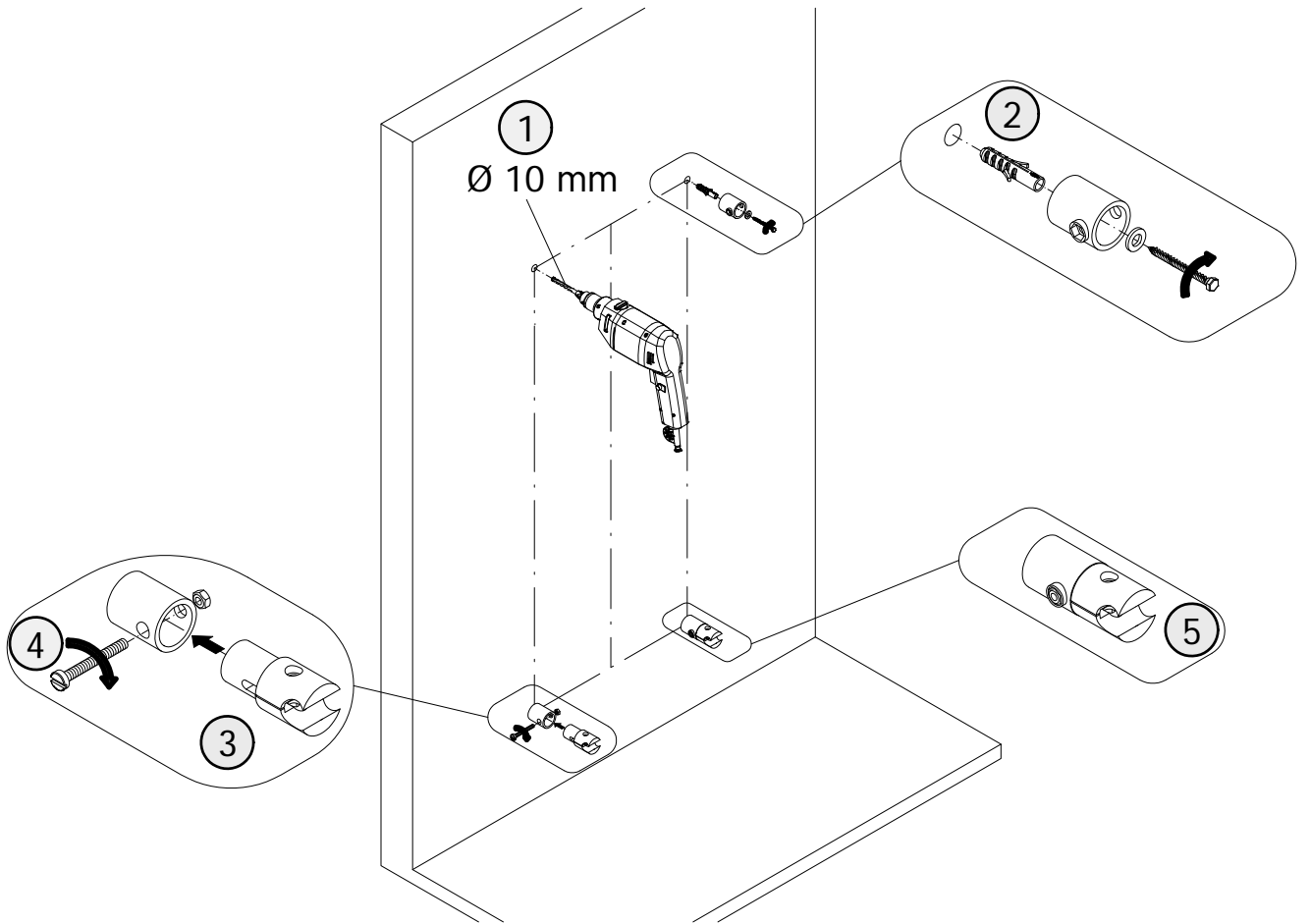

5 B

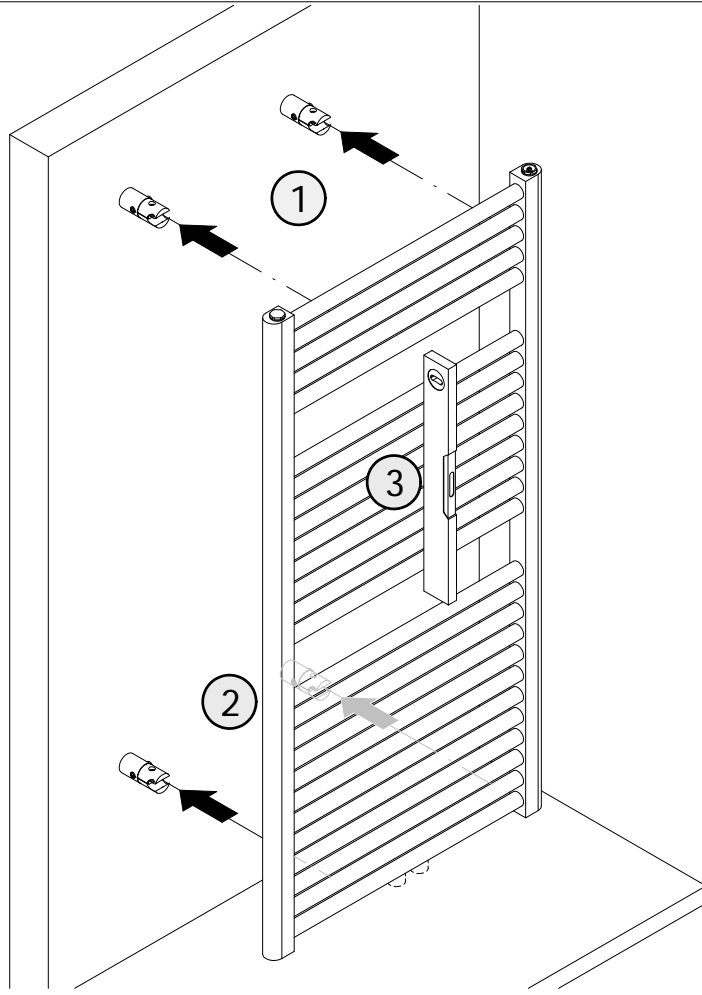

6 B

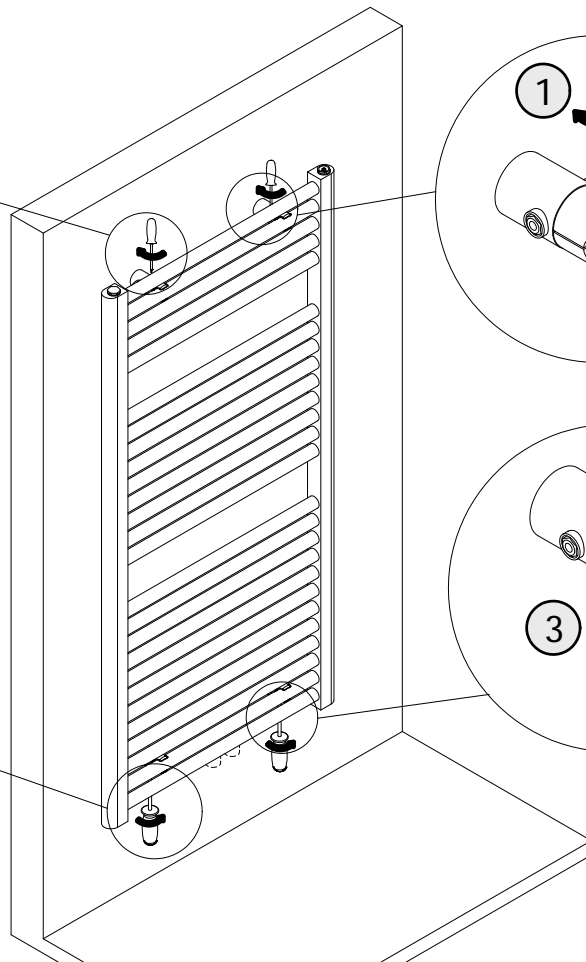
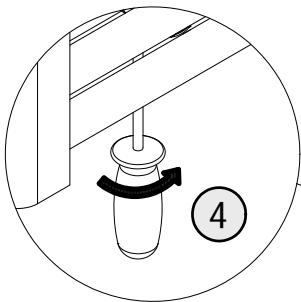
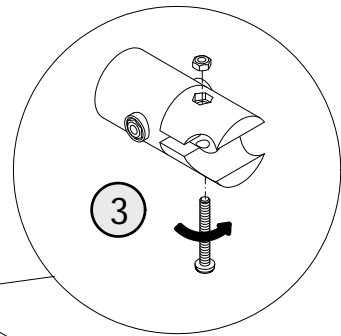
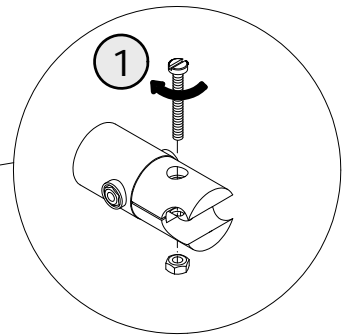
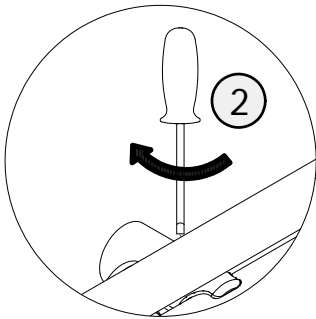

## FAQ

Störung	Ursache	Fehlersuche (Eingrenzung)	Abhilfe
Der Heizkörper wird nicht oder nur leicht warm.	→ gestörte Zirkulation	→ Luft im Heizkörper → Ausschlusssituation (Vorlauf / Rücklauf)  → Heizkörper ist unterversorgt	→ Entlüften Sie den Heizkörper. → Prüfen Sie, ob der Vorlauf / Rücklauf korrekt angeschlossen ist. → Führen Sie einen hydraulischen Abgleich durch.
Der Heizkörper macht Geräusche.	→ gestörte Zirkulation → Anlagendruck / Versorgungsleistung gestört	→ Luft im Heizkörper → Ventil regelt nicht → Voreinstellung der Ventile	→ Entlüften Sie den Heizkörper. → Prüfen Sie die Ventile und den Thermostatkopf. → Führen Sie einen hydraulischen Abgleich durch.
Der Heizkörper knackt in der Aufheiz- und Abkühlphase.	Ausdehnungsgeräusche bei Temperaturanstieg- bzw. Abfall, Spannungen im System		Hier liegt keine Gefahr vor und es ist keine Handlung erforderlich.
Der Heizkörper weist Mängel in der Montage oder in der Optik auf.			Wenden Sie sich an den Vertreter des Produktes.
Der Heizkörper soll mit einem Heizkostenverteiler ausgestattet werden.			Wenden Sie sich an den Hersteller des Heizkostenverteilers.

Problem	Reason	Trouble-shooting	Remedy
The radiator is luke warm	→ circulation blocked	→ Air in the radiator → Connection issue (reverse in/out flow) → Radiator needs bleeding	→ Bleed the radiator → Check the non return valve is connected properly → Perform a hydraulic balancing
The radiator makes unusual noises	→ circulation blocked → system pressure incorrect - adjust accordingly	→ Air in the radiator → Valve not regulating → Faulty valves	→ Bleed the radiator → Check the valves and thermostatic control → Perform a hydraulic balancing
The radiator "pulses" in the heating and cooling mode.	Expansion noises when using a heating rod or particles are circulating in the system.		Here, there is no risk and no action required.
The radiator has visual impairments/defects			Please contact the retailer of the product.
The radiator should be equipped with a heat cost allocator.			Contact the manufacturer of the heat cost allocator.

Dysfonctionnement	Cause(s)	Détection des erreurs	Solution(s) Proposée(s)
Le radiateur ne chauffe pas ou très peu.	→ circulation bloquée	→ présence d'air dans le radiateur → problème de connexion du circulateur → alimentation insuffisante	→ purger le radiateur. → vérifier si le clapet de retenue a été installé correctement. → effectuer un équilibrage hydraulique.
Le radiateur fait un bruit anormal.	→ circulation bloquée → pression / alimentation incorrecte	→ présence d'air dans le radiateur → la vanne thermostatique ne régule pas. → paramétrage de la vanne thermostatique.	→ purger le radiateur. → vérifier la vanne et la tête thermostatique. → effectuer un équilibrage hydraulique.
Craquement lors de la chauffe ou refroidissement du radiateur.	Bruits provoqués par la dilation des tuyaux lors de la chauffe, refroidissement, ou par des tensions au coeur du système.		Aucun danger, aucune action n'est nécessaire.
Le radiateur présente un défaut technique ou optique.			Prendre contact avec votre revendeur.
Le radiateur doit être équipé d'un système de répartiteur de frais de chauffage.			Prendre contact avec votre fournisseur d'énergie.

storing	oorzaak	storingzoeken (beperking)	oplossing
De radiator wordt niet of slechts gedeeltelijk warm.	→ onderbroken circulatie	→ lucht in de radiator → verwisseling aanvoer/retour) → watertoevoer naar radiator is te gering	→ ontluicht de radiator. → controleer of aanvoer/retour juist is aangesloten. → maak een hydraulisch vergelijk.
De radiator maakt geruis.	→ gestoorde circulatie → installatiedruk / verzorgingscapaciteit onvoldoende	→ lucht in de radiator → radiatorkraan regelt niet juist. → voorinstelling van radiatorkraan niet juist.	→ ontluicht de radiator. → controleer de radiatorkraan en thermostaatkop. → maak een hydraulisch vergelijk.
De radiator "knakt" bij het warmworden en afkoelen.	Uitzettingsgeluiden bij temperatuurstijging resp. afkoeling, spanning in het systeem.		Hier bestaat geen gevaar en is geen ingreep noodzakelijk.
De radiator heeft onvolkomenheden bij de montage of optisch.			Neem contact op met de verkoper van het product.
De radiator moet worden voorzien van een warmtekostenverdelers.			Neem contact op met de fabrikant van de warmteleverancier.



Duschservice  
Zum Hohlen Morgen 22  
59939 Olsberg  
Deutschland / Germany / Allemagne / Duitsland



Ersatzteilbestellung:  
Fax 02962 / 972-4260



Allgemeine technische Probleme:  
Telefon 02962 / 972-40



E-Mail:  
ersatzteile@duschservice.de